

Important Information:

These instructions and dimensions and those in the accompanying booklet are provided for guidance only. They may require adapting to individual site requirements and the design of the tank system.

When the filter is installed to provide the overflow, the rainwater divert and overflow pipe must be horizontal and level. When a separate overflow is installed ensure the required air gap is maintained.

If the downpipe is over 4 m to Frogmouth entry, install an elbow entry to reduce the velocity of rainwater flowing from the roof line.

It is recommended that the push fit adaptors are secured with PVC cement/glue or a screw fixing. The adaptors can be painted to match the colour of the downpipe. They should be washed in soapy water and prepared with a primer coat before painting.

Frogmouth installation Instructions

1. Mark Frogmouth Filter™ Location

Designed for roof collection area of 120m max.

If water tank has an overflow pipe fitted:

- Mark a line on the downpipe 440mm above the invert of the overflow
- Mark a second line 460mm below the first line

If water tank does not have an overflow pipe fitted:

- Mark a line on the downpipe 300mm above the invert of the inlet pipe
- Mark a second line 460mm below the first line

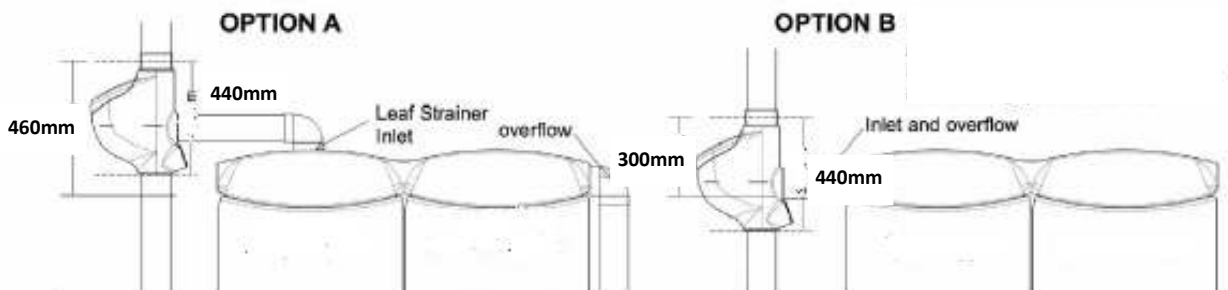

2. Prepare Frogmouth Filter™ for Installation

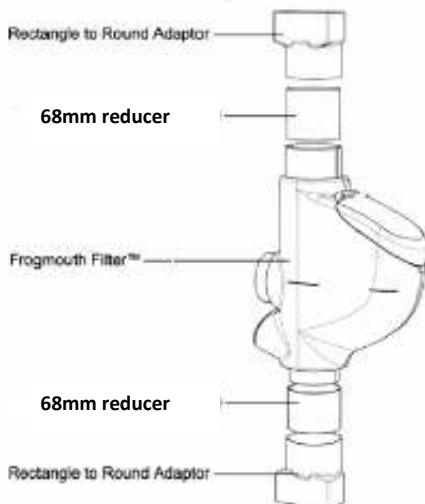

- If required, attach rectangle-to-round adaptor



- Glue upper PVC pipe to adaptor, and glue adaptor to downpipe
- Glue lower PVC pipe to adaptor and glue adaptor to downpipe

3. Prepare Downpipe

• Cut downpipe on previously marked lines and file rough edges

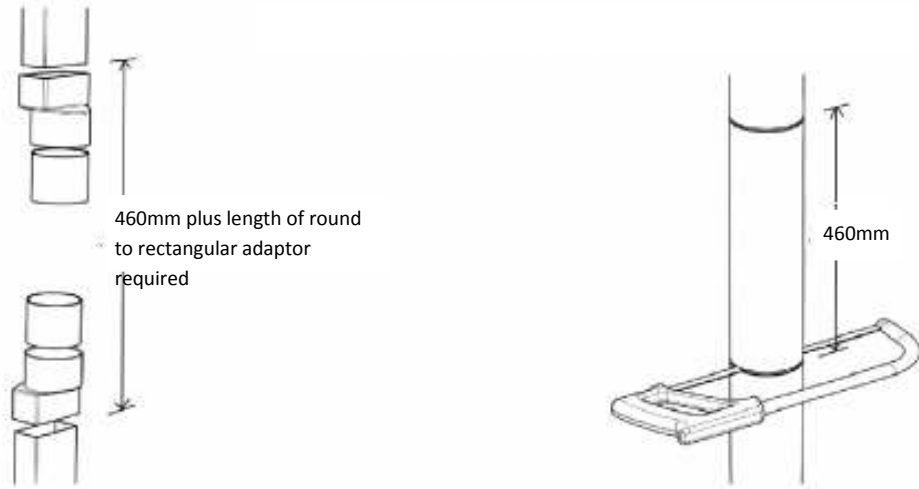

4. Mount Frogmouth Filter™ on to Downpipe

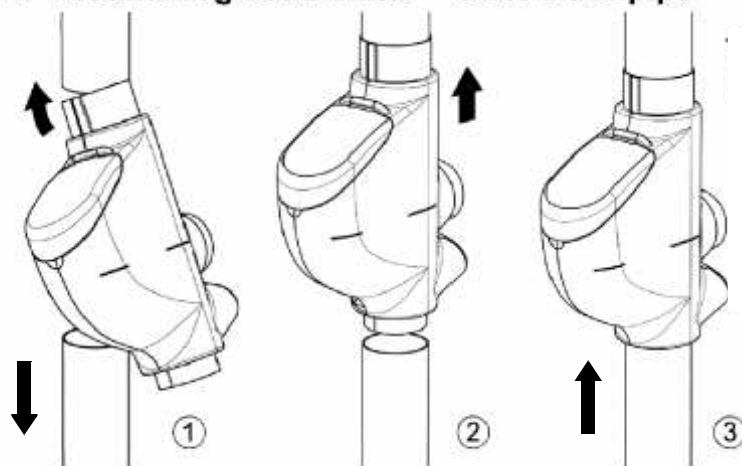

Filters are supplied with a push fit reducer to interconnect with a 68mm downpipe. Unfasten the support brackets on the lower section of pipe. Lower the pipe to fit the filter and reducer, raise the pipe again and secure with a standard wall mounted downpipe bracket.

5. Mount Pipe on to Flange

Apply PVC cement to the flange of the Frogmouth

Attach 68mm reducer onto the flange

Attach 68mm pipe to tank

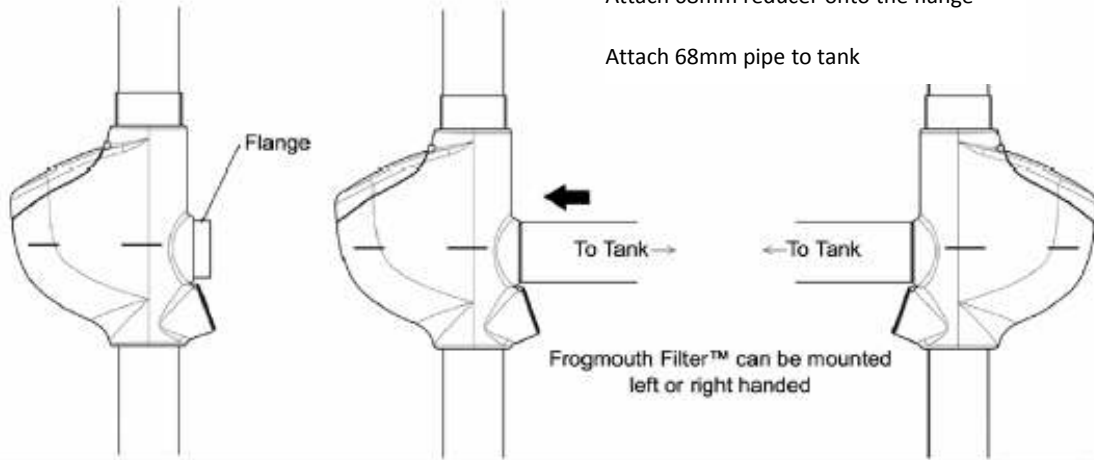

6. Extreme Weather Events

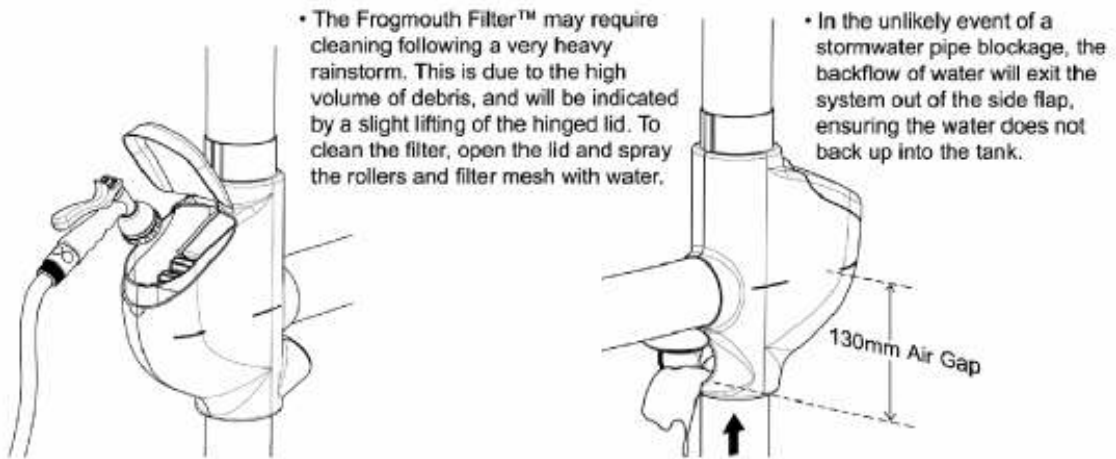

For further information contact

Halsted Rain Ltd
Halsted House
Lock Chase
Blackheath
London SE3 9HB

Direct Line: 07900 427450
Switchboard: 0208 318 0957
www.halstedrain.com